

Braytron

TECHNISCHES DATENBLATT

MODELL

BV01-00132

BESCHREIBUNG

BRY-S011R-11H-11xG9-OPL-PENDANT LIGHT

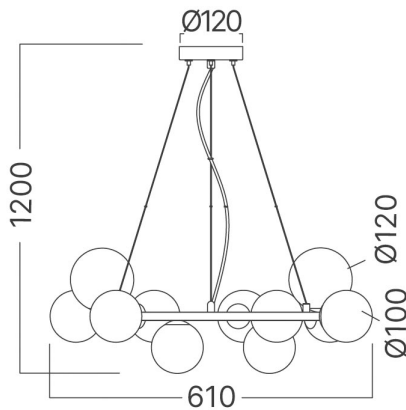

BRAYTRON SRL

MUNICIPIUL BUCUREȘTI, SECTOR 6, BLD. IULIU MANIU, NR.616, CORP B, ET.1,BUCUREȘTI, Sector 6(RO)

info@braytron.com

www.braytron.com

Pagina 1 din 2

Allgemeine Merkmale

Modell	:	BV01-00132
Hauptkategorie	:	Dekorative CLS
Unterkategorie	:	Glas OPL
Typ	:	Pendant Light
Gehäusefarbe	:	Black
Sockel/Fassung	:	G9
Garantie	:	2 Years
Klasse	:	CLASS I
IP (Schutzart)	:	IP20

Product Characteristics

Max. Leistung	:	Max.11x10 w
---------------	---	-------------

Elektrische Eigenschaften

Spannung	:	220-240V 50/60Hz
Material	:	Metal-Glass
Arbeitstemperatur	:	-20°C ~ +40°C

Dimensions & Weight

Länge	:	610 mm
Breite	:	610 mm
Höhe	:	1200 mm
Gewicht	:	2450 gr

Paket-Informationen

Nettogewicht	:	2,45 kgs
Bruttogewicht	:	3,75 kgs
Stückzahl pro Karton (PCS/CTN)	:	1
Länge	:	55 cm
Breite	:	50 cm
Höhe	:	29 cm
EAN-Code	:	5949097743290