

Braytron

TECHNICAL DATA SHEET

MODEL	BZ01-00730
DESCRIPTION	BRY-ELK-FAN-SQ1-10"-RND-EXHAUST FAN

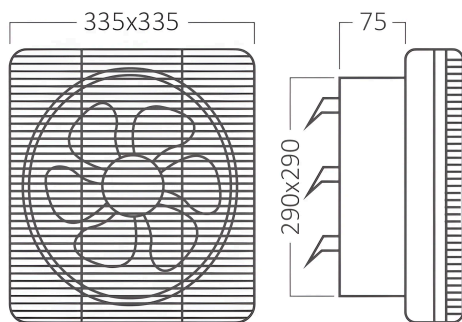
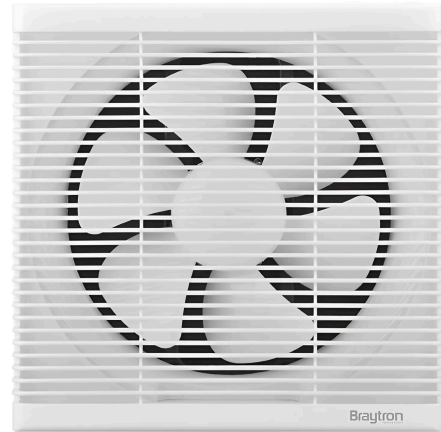
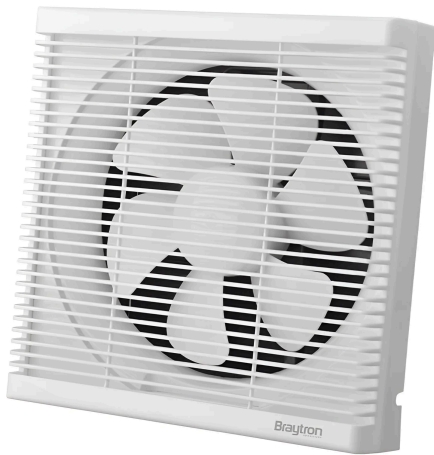

BRAYTRON SRL

MUNICIPIUL BUCUREȘTI, SECTOR 6, BLD. IULIU MANIU, NR.616, CORP B, ET.1,BUCUREȘTI,Sector 6(RO)
info@braytron.com
www.braytron.com

General Characteristics

Model No : BZ01-00730
Main Family : Electrical
Sub Family : Fan

Package Informations

EAN : 5949097740169

BRAYTRON SRL

MUNICIPIUL BUCUREȘTI, SECTOR 6, BLD. IULIU MANIU, NR.616, CORP B, ET.1,BUCUREȘTI,Sector 6(RO)
info@braytron.com
www.braytron.com